

Specification sheet LX 1091

Roof drainage systems

Series 84 DRAINLET[®]

Emergency drainage

Gravity flow

Silent Power

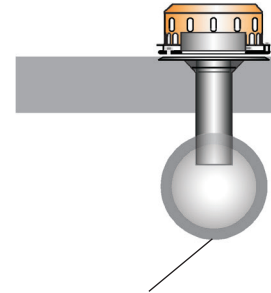

Horizontal manifold with gradient

Discharge rate:	5,9 l/sec
Water height:	75 mm
Roof penetration:	-
Diameter:	DN 100
LX-Number:	LX 1091
Weir height:	35 mm
Drain:	ventilated
Downpipe:	ventilated
Downpipe height:	-
Drainage:	in sewer

LX 1091 Piece list

1 x Art.-No. choose drain on page two!

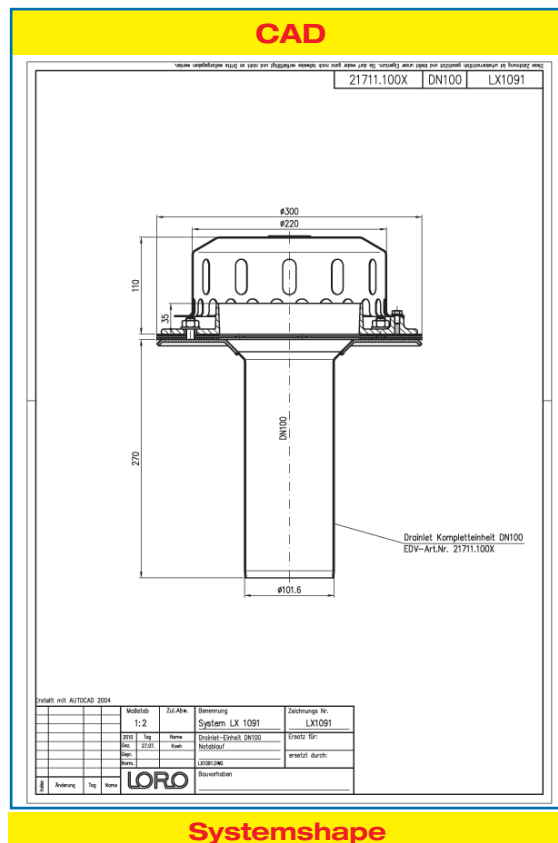
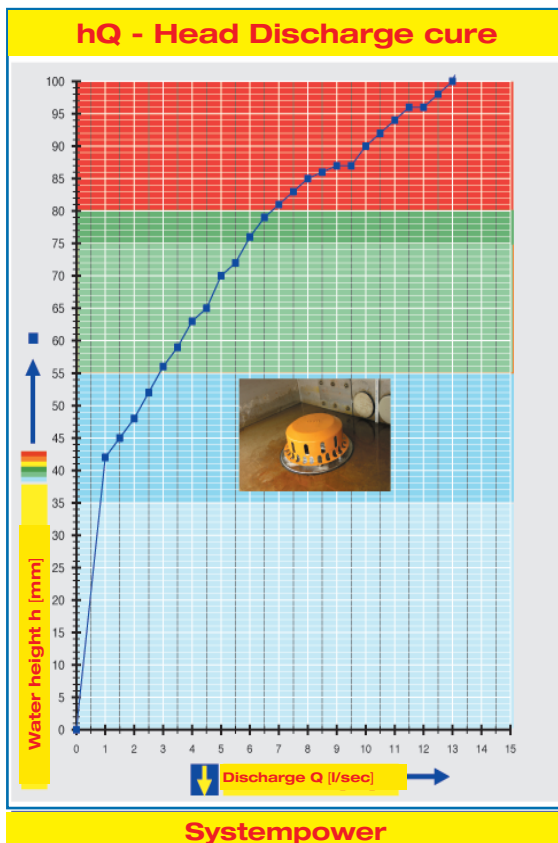

Water height	mm	10	15	20	25	30	35	40	45	50	55	60	65	70	75	80	85	90	95
Discharge	l/sec							0,9	1,5	2,2	2,9	3,6	4,5	5,0	5,9	6,8	8,0	10,0	11,2
Silent Power																			

Choose drain for piece list on page one!

DN 100

without insulation

LX1091-5X

Drain Art.-No. 21711.100X

with clamping flange
one-piece



LX1091-6X

Drain Art.-No. 21721.100X

with clamping flange
two-piece

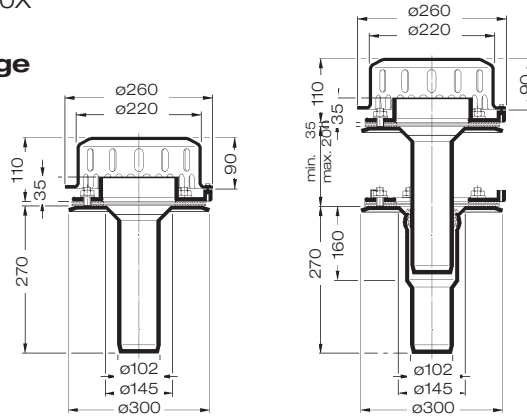

with insulation

LX1091-7X

Drain Art.-No. 21712.100X

with clamping flange
one-piece



LX1091-8X

Drain Art.-No. 21722.100X

with clamping flange
two-piece

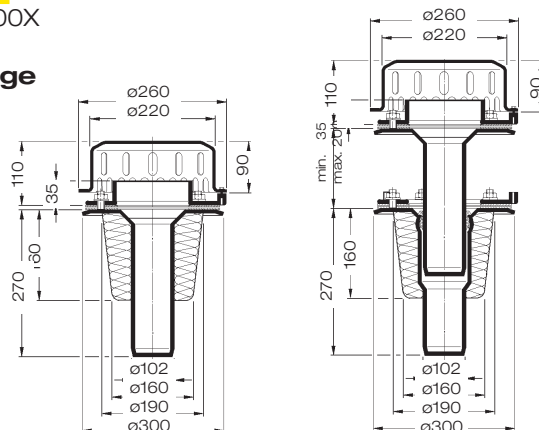

with insulation and heating

LX1091-9X

Ablauf Art.-Nr. 21713.100X

with clamping flange
one-piece



LX1091-10X

Ablauf Art.-Nr. 21723.100X

with clamping flange
two-piece

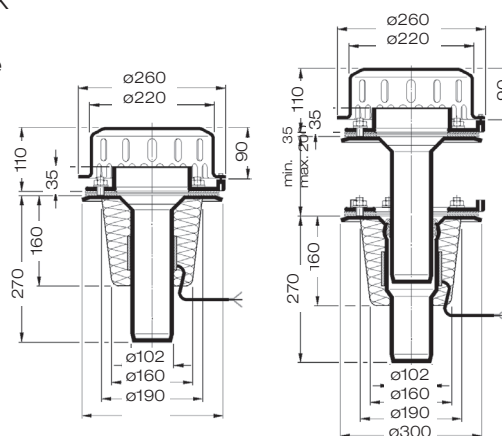

Heat tracing: Lorowerk recommends to check all drains and pipes with regard to their frost-sensibility. Where necessary, these parts should be upgraded with heat tracing.